

FOTEK AT MARK SENSOR

- ⊕ KEY: SETTING/PLUS KEY 設定/增強鍵
- ⊖ KEY: SETTING/MINUS KEY 設定/減弱鍵
- OP LED: OPERATING PILOT 動作指示燈
- PL LED: POWER/STATUS PILOT 電源指示燈

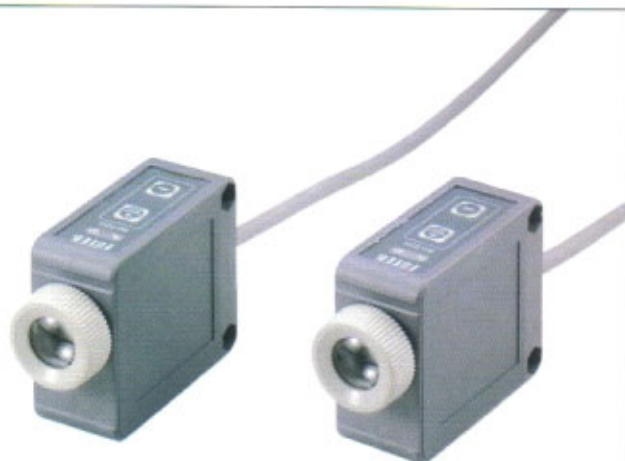





■ Specification

Mode 型號	MS-02W	MS-02W-H	MS-02W-M12	MS-02WH-M12
Setting Distance 設定距離	25.0mm			
Fmitter 發光源	White Light Led 白光			
Light Spot 光點	2.0 ϕ			
Response Time 應答時間	0.25ms	0.1ms	0.25ms	0.1ms
Illumination 耐外亂光	Lamplight < 5,000 Lux; Sunlight < 10,000 Lux			
Operating Voltage 工作電壓	10~30VDC, Ripple < 20% of p-p			
Current Consumption 耗電流	40.0mA Max			
Outout Method 輸出方式	NPN & PNP Two Output			
Output Status 輸出狀態	NO or NC Changeable			
Output Current 輸出電流	150.0mA Max			
Leakage Current 漏電流	$\leq 0.8\text{mA}$			
Residual Voltage 殘留電壓	$\leq 0.8\text{v}$			
Protection Circuit 保護電路	Short Circuit & Polarity Reversed Protection			
Connection Method 掃線方式	4C/5.0 ϕ \times 2m		M12 Connector	
Housing Material 外亮材質	Intensive PBT			
Protection Class 保護等級	Ip-65			
Circumstance 工作環境	-20 $^{\circ}\text{C}$ ~ +60 $^{\circ}\text{C}$; 35~85% RH			
Weight 重量				

■ Setting of Sensitivity / 感度設定



Setting On Background/背景動作設定

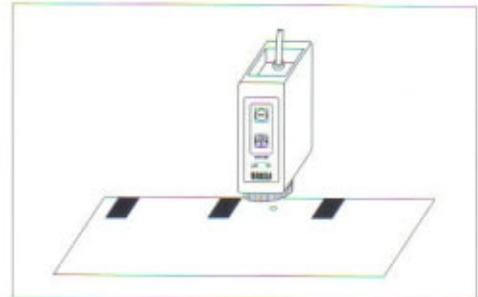

After PRESSING The  Key , The LED " PL " Flicks Slowly ,
Then Please Press The  Key to Finish The Setting Of Sensitivity
< LED " PL " & " OP " Turn On >

按住  鍵 3 秒後, " PL " LED 會慢閃
再按  鍵即可完成感度設定
< " PL " 及 " OP " LED 都會亮著 >



Setting On Mark Point/標誌點動作設定

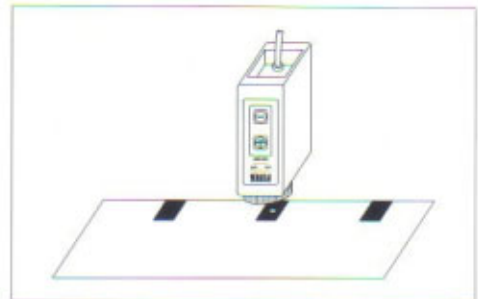

After PRESSING The  Key , The LED " PL " Flicks Slowly ,
Then Please Press The  Key to Finish The Setting Of Sensitivity
< LED " PL " Turn On , LED " OP " Off >

按住  鍵 3 秒後, " PL " LED 會慢閃
再按  鍵即可完成感度設定
< " PL " LED 亮著 " OP " LED 熄滅 >



Setting On Two Position/兩點設定

SET 1 : On the Mark Point , After Pressing The  Key 3 Sec.,
The LED " PL " Flicks Slowly

SET 2 : On the Background ,
High Sensitivity To Press The  Key
Low Sensitivity To Press The  Key

SET 1 : 再標誌點上按  鍵 3 秒, " PL " LED 會慢閃

SET 2 : 在背景上高感度設定按  鍵, 低感度設定按  鍵



Remarks/備註

1 > If LED " PL " Flicks Fastly After Finishing Setting , It is The Maximun Sensitivity Condition.

完成設定後 " PL " LED 快閃, 表示設定成最大感度狀態

2 > On The Detecting Condition , If Pressing The  Key May Add The Sensitivity

Or Pressing The  Key May Reduce The Sensitivity

在檢測狀態, 按  鍵可以增加感度, 按  鍵可以減弱感度

3 > To Change The Output Status , Please Keep On Pressing The  Key And Pressing The  Key To Change The Output Status .

< If Keep On Pressing The  Key Over 3 Sec. Will Enter To The Setting Condition >

如果要改變輸出狀態, 請按住  鍵再按  鍵即可改變輸出狀態。

< 注意, 不要持續按  鍵超過3秒, 否則會進入感度設定狀態 >

4 > On The Detecting Status , LED " PL " Is The Pilot Of Stability

在檢測狀態, " PL " LED 是穩定指示燈

Output Circuit/輸出迴路

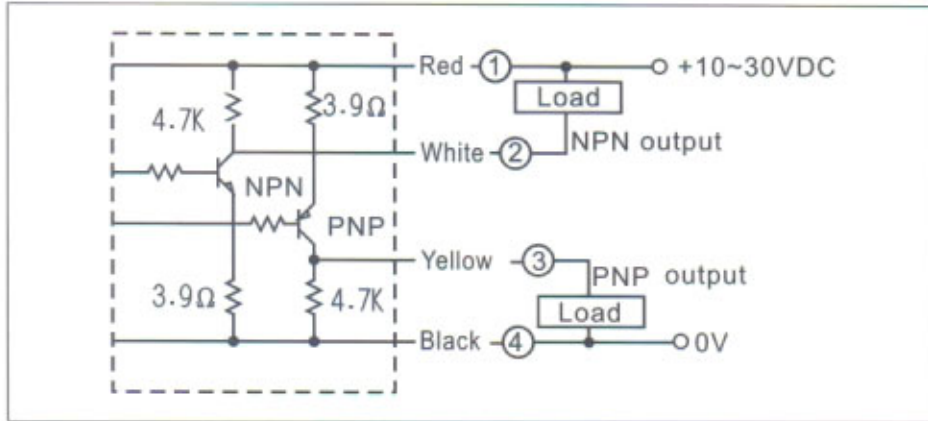

Dimension/尺寸圖

